

Hypertherm®

MAXPRO200®



MAXPRO200 hand torch consumables

Air-mild steel/Stainless steel/Aluminum

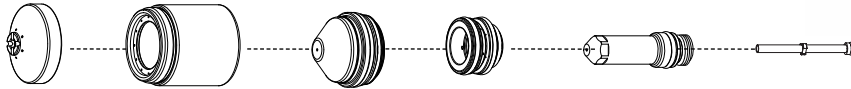

	Shield	Shield cap	Nozzle	Swirl ring	Electrode	Water tube
50 A	420063	220935	220890	220529	220528	220521
130 A	420061	220935	220892	220488	220487	220521
200 A	420058	220935	420044	220488	220937	220521
200 A gouging	420067	220935	420066	220488	220937	220521

O₂ – mild steel

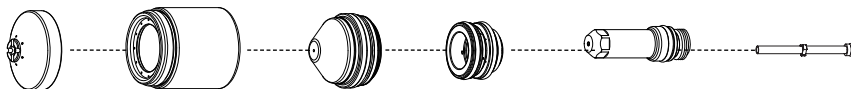

	Shield	Shield cap	Nozzle	Swirl ring	Electrode	Water tube
50 A	420063	220935	220891	220529	220528	220521
130 A	420062	220935	220893	220488	220487	220521
200 A	420059	220935	220831	220834	220937	220521



MAXPRO200 65° hand torch



MAXPRO200 90° hand torch

TECHNOLOGIES

- Chambered Swirl Ring**
- Conical Flow™**
- CoolFlow™**
- LongLife®**
- TrueFlow™**
- Vented Shield**
- HyLife®**
- Tool free lead connection**
- Tool free nozzle**
- Inline valve process**

MAXPRO200[®]

Hand torch assembly options

Standard leads

Lead length	Part number
7.5 m (25')	428131
15 m (50')	428132
23 m (75')	428133
30 m (100')	428134

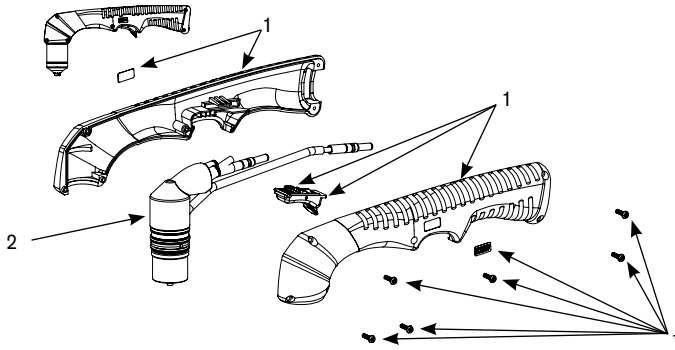

90 degree hand torch options

	Description	Part number
1	Handle replacement kit	228985
2	Torch main body	428109
	Handheld consumables starter kit	428014

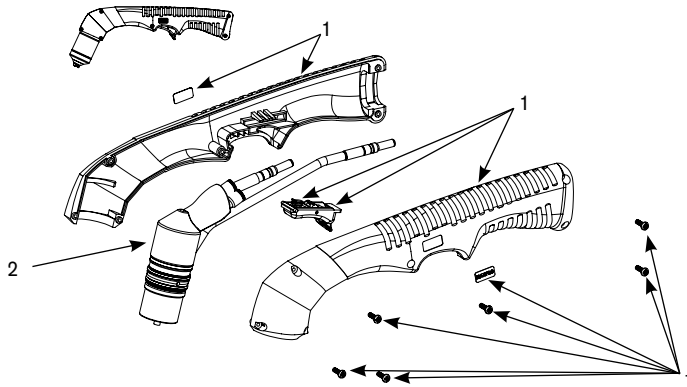

65 degree hand torch options

	Description	Part number
1	Handle replacement kit	228986
2	Torch main body	428108
	Handheld consumables starter kit	428014

Hypertherm, MAX, Conical Flow, CoolFlow, LongLife, TrueFlow and HyLife are trademarks of Hypertherm Inc. and may be registered in the United States and/or other countries

Hypertherm[®]

www.hypertherm.com

Hypertherm®

MAXPRO200®



MAXPRO200 machine torch consumables

Air – Mild steel/Stainless steel/Aluminum

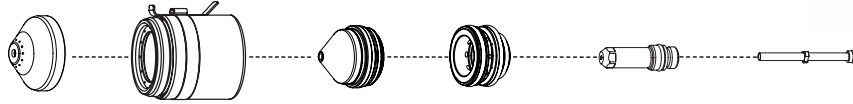

	Shield	Shield cap	Nozzle	Swirl ring	Electrode	Water tube
50 A	220532	220936 220935 without tab	220890	220529	220528	220521
130 A	220536	220936 220935 without tab	220892	220488	220487	220521
200 A	420045	220936 220935 without tab	420044	220488	220937	220521

O₂ – Mild steel

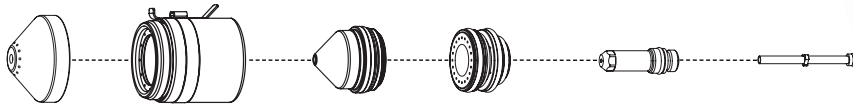

	Shield	Shield cap	Nozzle	Swirl ring	Electrode	Water tube
50 A	220532	220936 220935 without tab	220891	220529	220528	220521
130 A	220491	220936 220935 without tab	220893	220488	220487	220521
200 A	220832	220936 220935 without tab	220831	220834	220937	220521

N₂ – Stainless steel/Aluminum

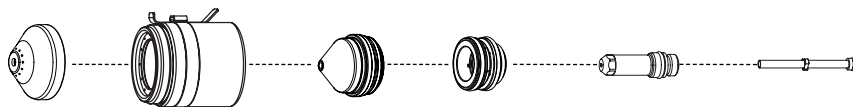

	Shield	Shield cap	Nozzle	Swirl ring	Electrode	Water tube
130 A	220536	220936 220935 without tab	220892	220529	020415	220521
200 A	420045	220936 220935 without tab	420044	220529	020415	220521



MAXPRO200 quick-disconnect machine torch



MAXPRO200 straight machine torch

TECHNOLOGIES

- Chambered Swirl Ring**
- Conical Flow™**
- CoolFlow™**
- LongLife®**
- TrueFlow™**
- Vented Shield**
- HyLife®**
- Tool free lead connection**
- Tool free nozzle**
- Inline valve process**

MAXPRO200®

Machine torch assembly options

Standard leads

Lead length	Part number
7.5 m (25')	229477
15 m (50')	229478
23 m (75')	229479
30 m (100')	229480

Mounting sleeves

Description	Length	Diameter	Part number
Standard	279.4 mm (11")	50.8 mm (2")	220943
Standard	279.4 mm (11")	44.45 mm (1.75")	220942

Torch options

Description	Part number
Straight torch (standard)	420087
Quick-disconnect receptacle (option)	420033

HyPro2000 Quick-disconnect torch (option)

220921

Additional parts available (not shown)

Machine torch (straight torch, set of 200 A consumables)	228937
Consumables removal tool	104119
Machine torch consumables starter kit	428013
Silicon lubricant for o-rings	027055

Mounting sleeve
(2" outside
diameter)

Mounting sleeve
(1.75" outside
diameter)

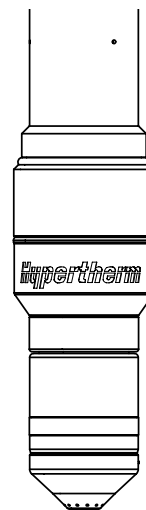
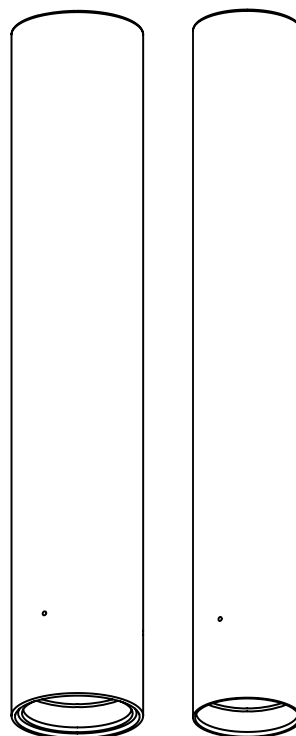

Quick
disconnect

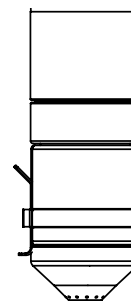

MAXPRO200
torch

Hypertherm, MAX, Conical flow, CoolFlow, HyLife, LongLife, and TrueFlow are trademarks of Hypertherm Inc. and may be registered in the United States and/or other countries

Hypertherm®

www.hypertherm.com

Extreme bevel consumables

For MAXPRO200 air and oxygen plasma cutting systems

MAXPRO200 extreme bevel consumables



Air – Mild steel

Amperage	Shield	Shield cap	Nozzle	Swirl ring	Electrode	Water tube
130 A	420735	220936	420829	220488	420824	420823
		220935 without tab				
200 A	420737	220936	420734	220488	420732	420823
		220935 without tab				

Oxygen – Mild steel

Amperage	Shield	Shield cap	Nozzle	Swirl ring	Electrode	Water tube
130 A	420735	220936	420828	220529	420824	420823
		220935 without tab				
200 A	420737	220936	420733	220488	420732	420823
		220935 without tab				



MAXPRO200 torch with standard consumables

MAXPRO200 torch with extreme bevel consumables

For more information, visit: www.hypertherm.com

Hypertherm, HyPerformance and MAXPRO are trademarks of Hypertherm, Inc. and may be registered in the United States and/or other countries. All other trademarks are the property of their respective owners.

Please visit www.hypertherm.com/patents for more details about Hypertherm Associates patent numbers and types.

© 10/2023 Hypertherm Inc. Revision 2
898040

As 100% Associate owners, we are all focused on delivering a superior customer experience. www.hyperthermassociates.com/ownership

Environmental stewardship is one of Hypertherm Associates' core values. www.hyperthermassociates.com/environment

100% Associate-owned

